

Series SOPAC

Mineral oil separators for small units.

Oils and hydrocarbons monobloc separator nominal max flow 1,5 l/s.

in compliance with UNI EN 858 brand **CE**

Technical specifications

Supply of a separation tank type EMS WATER TECHNOLOGY series SO/AC, dimensioned according to the prescriptions of the EN 858-1 regulations, class 1, branded CE, prefabricated for the treatment of water coming from waterproofed service areas, made of highly resistant reinforced concrete, complete with an AISI deflector for the incoming sewage and shutter valve with coalescence filter for the outgoing sewage, cover slab suitable for car passage and manholes for inspection with cast iron D400 cover

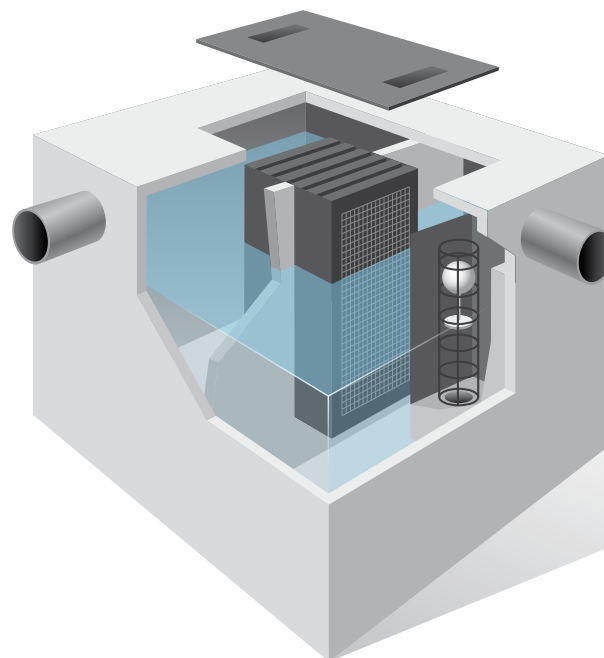

SOPAC plants for service stations, car parks, covered garages, car washes and machines shops with water jet cleaners

NOMINAL FLOW l/s	MAX SERVICED SURFACE mq	MAX CARS n.	LENGTH cm	SEPARATOR DIMENSIONS			SEPARATOR WEIGHT q.li
				WIDTH cm	HEIGHT cm		
1,5	200	15	120	100	100	15	

The values stated are just for information. EMS WATER TECHNOLOGY retains the right to change them at any time.